



Brušenje in ostrenje orodij

DIACOM 1V1

D x X x U/V°

Brusno orodje - disk

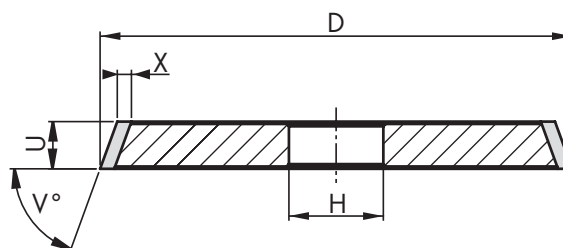
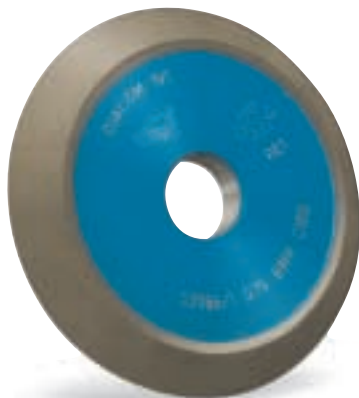

D	X	U	V°
40	1.5 2 3	5	70
75	1.5 2 3	6	45 70
75	1.5 2 3	10	70
90	1.5 2 3	6	70
90	1.5 2 3	10	70
100	1.5 2 3	6	45 70
100	1.5 2 3	10	70
125	1.5 2 3	6	45
125	1.5 2 3	10	45 70
125	5	10	80

DIACOM 1FF1

D x T x X/R x H

Brusno orodje - disk

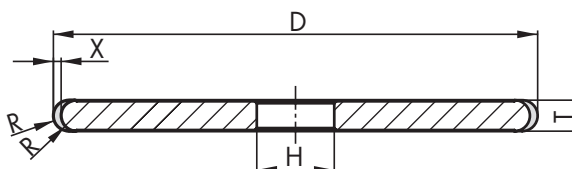

D	R	X	T
75	2	2	4
75	4	2	8
125	3	2	6
125	4	2	8
125	8	2	16
150	2.5	2	5
150	10	2	20



DIACOM 4A2

D x W x X x H

Brusno orodje - disk

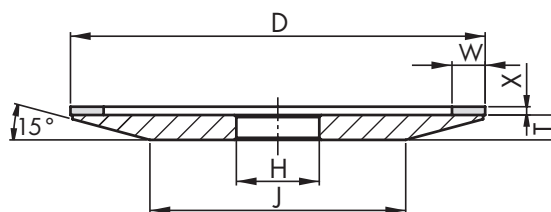

D	X	T	J
75	2 3 4	6	37 40 44
100	2 3 4	8	47 50 54
125	2 3 4	8	72 75 79
150	2 3 4	8	97 100 104
175	2 3 4	10	107 111 114

DIACOM 4ET9

D x W x X x H

Brusno orodje - disk

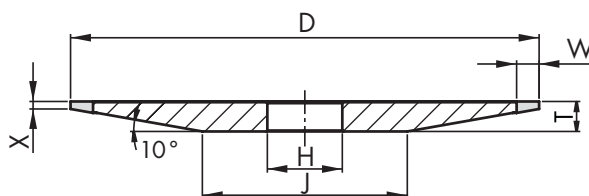

D	X	W	T	J
50	1	6	4	14
50	1 2	5	4	14 25
75	1 2	6	5	27 39
100	1 2	6	6	41 52
125	1 2	6	8	43 55
125	1 2	6	8	43 55
150	1 2	6 10	10	43 57



Brušenje in ostrenje orodij

DIACOM **4BT9**

D x W x X x H

Brusno orodje - disk

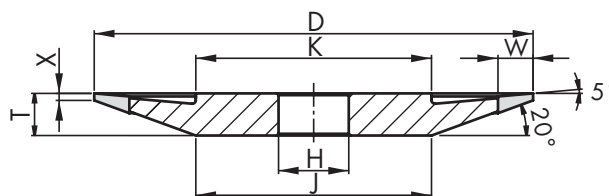
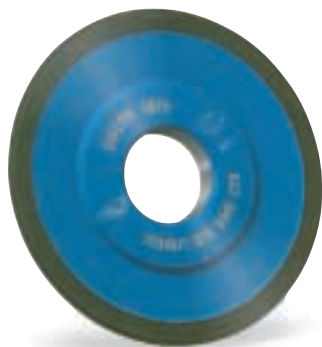

D	X	W	T	J
50	1 2	10	6	20 26
75	1 2	6 10	8	34 40
100	1 2	6 10	10	48 54
125	1 2	6 10	12	62 68
150	1 2	6 10	14	76 82

DIACOM **6A9**

D x X x U x H

Brusno orodje - lonec

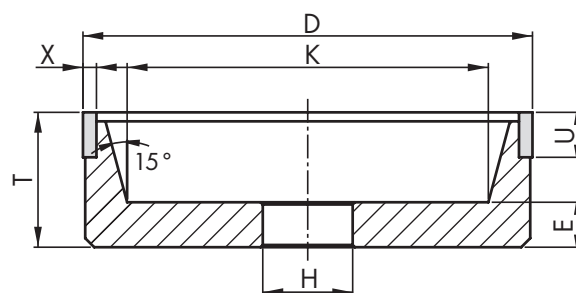

D	X	U	T	E	K
50	2 3	6 10	20	8	37 35
75	2 3	6 10	25	10	60 58
100	2 3	6 10	30	10	82 80
125	2 3 4	6 10	30	10	107 105 103
150	2 3 4	6 10	35	10	130 128 126



DIACOM 6V9

D x X x U x H

Brusno orodje - lonec

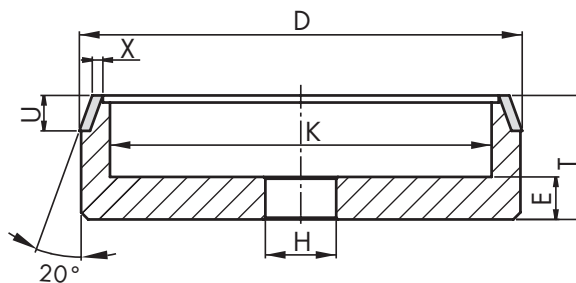

D	X	U	T	E	K
75	2	6	25	8	63
75	3	6	25	8	61
75	2	10	25	8	60
75	3	10	25	8	58
100	2	6	30	10	88
100	3	6	30	10	86
100	2	10	30	10	85
100	3	10	30	10	83
125	2	6	35	10	113
125	3	6	35	10	111
125	2	10	35	10	110
125	3	10	35	10	108
150	2	10	35	10	135
150	3	10	35	10	133

DIACOM 9A3

D x W x X x H

Brusno orodje - disk

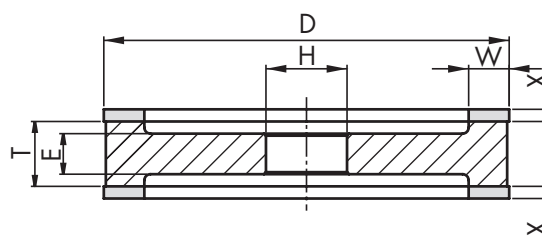

D	W	X	T	E
75	6	2 3 4	22	10
100	6 10	2 3 4	22	10
125	6 10	2 3 4	22	10
150	10 15	2 3 4	25	14
175	6 10 15	2 3 4	25	14
200	10 15	3 4	30	18



Brušenje in ostrenje orodij

DIACOM 9U1

D x T x W x X x H
Brusno orodje - disk

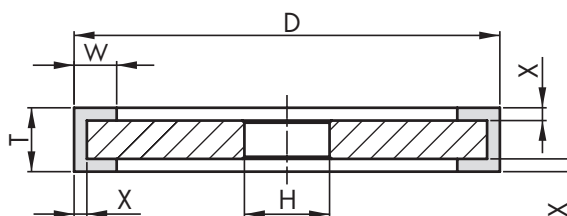

D	T	W	X
75	10 15	6 10	2 3
100	10 15	6 10	2 3
125	10 15	6 10	2 3
150	10 15	6 10	2 3

DIACOM 11V9

D x X x U x H
Brusno orodje - lonc konični

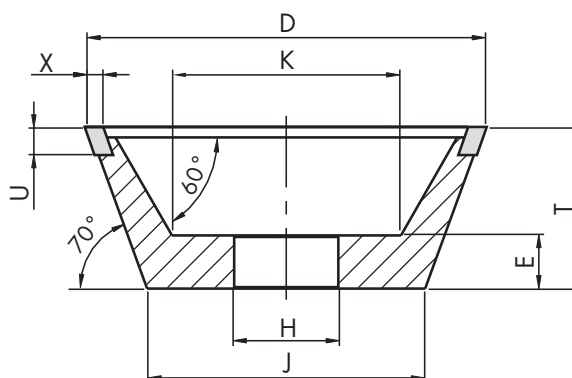

D	X	U	T	E	K	J
40	1.5 2 3	5	18	8	22 21 19	26
50	2 3	5	20	8	29 27	34
75	1.5 2 3	6 10	30	10	46 45 43	52
90	1.5 2 3	6 10	35	10	55 54 52	64
100	1.5 2 3	6 10	35	10	65 64 62	74
125	1.5 2 3	6 10	40	10	84 83 81	95
150	1.5 2 3	6 10	50	10	98 97 95	113



DIACOM 12A9

D x W x X x H

Brusno orodje - disk

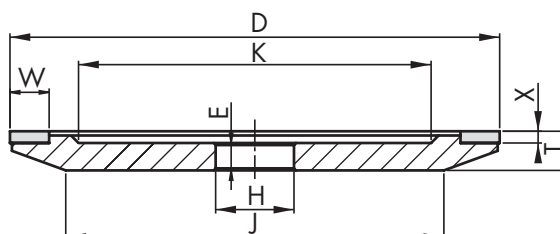

D	X	W	T	E	K(W,E)	J(X)
50	2 3		10			16 22
	3			7 8	28 30	
	5			7 8	24 26	
75	2 3		10			41 47
		6		7 8	47 49	
75		10		7 8	39 41	
100	2 3		10			66 72
		6		7 8	72 74	
100		10		7 8	64 66	
125	2 3		10			91 97
		6		7 8	97 99	
		10		7 8	89 91	
150	2 3		12			105 111
		6		9 10	122 124	
		10		9 10	114 116	
175	2 3		12			130 136
		6		9 10	147 149	
		10		9 10	139 141	
200	2 3		12			155 161
		6		9 10	172 174	
		10		9 10	164 166	



Brušenje in ostrenje orodij

DIACOM 12A2-45°S

D x W x X x H

Brusno orodje - krožnik

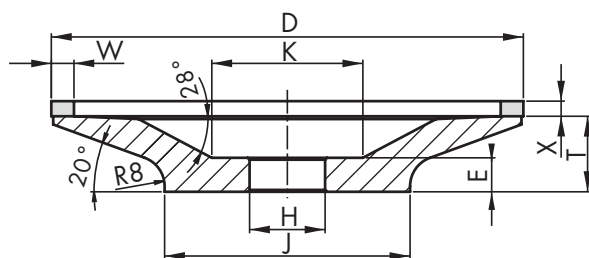

D	X	W	T	E	K	J
100	2 3 4	6	18	8	34	49
125	2 3 4	6	19	9	56	74
150	2 3 4	6	20	10	78	99
175	2 3 4	6	20	10	93	114
200	2 3 4	6	21	11	128	149

DIACOM 12V9-25°

D x X x U x H

Brusno orodje - krožnik

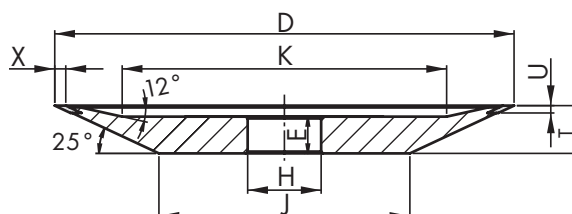

D	X	U	T	E	K	J
100	3	2	12	10	72	50
125	3	2	13	10	88	70
150	3	3	16	10	86	82



DIACOM 12V9-45°

D x X x U x H

Brusno orodje - lonec

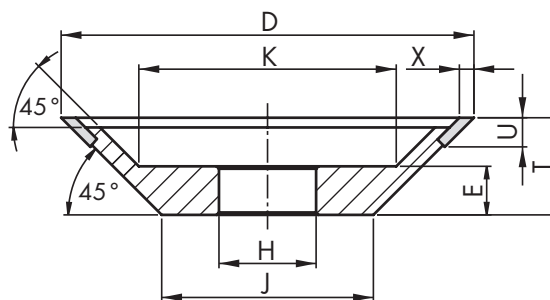

D	X	U	T	E	K			J
50	2	5	15	8	26			19
75	1.5 2 3	6	20	8	42 41	39		34
85	1.5 2 3	6	20	10	56 55	53		44
100	1.5 2 3	6 10	20	10	71 70	68		59
125	1.5 2 3	6 10	25	10	86 85	83		74
150	1.5 2 3	6 10	25	10	111 110	108		99
175	1.5 2 3	6 10	25	10	136 135	133		124

DIACOM 12C9

D x W x X/U x H

Brusno orodje - lonec

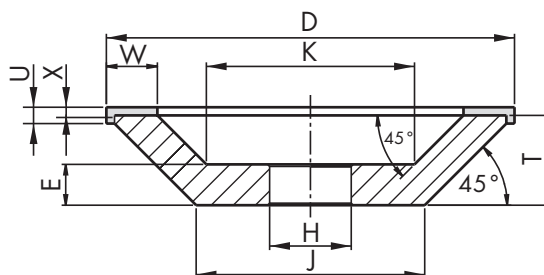

D	X	W	T	E	U	K			J
50	1	3 5	18	10	2	28 24			14
75	2	6 8 10	22	10	4	39 35 31			31
100	2	6 8 10 12.5	22	10	4	64 60	56 51		56
125	2	6 8 10 12.5	22	10	4	89 85	81 76		81
150	2	8 10 12.5 15	22	10	4	110 106	101 96		106



Brušenje in ostrenje orodij

DIACOM 15V9

D x X x U x H

Brusno orodje - krožnik

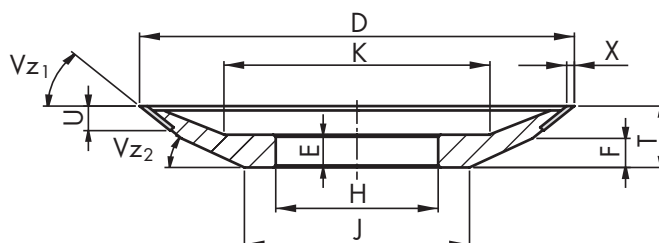

D	X	U	T	E	K	Vz ₁	Vz ₂	Vn	J ₁	F	J
85	2	6	15	8	52	45	30	27	69	7	45
75	2	6	13	6	38	45	30	22	59	5	43
75	3	6	13	6	38	45	30	25	59	5	43
100	2	6	20	11	57	45	30	25	84	12	42
100	3	6	20	11	57	45	30	27	84	12	42
150	2	6	20	11	76	30	20	14	122	12	56
150	3	6	20	11	76	30	20	15	122	12	56
150	2	6	20	11	79	45	30	14	134	12	92
150	3	6	20	11	79	45	30	15	134	12	92
175	2	8	25	11	85	45	30	18	155	15	103
200	2	6	25	11	95	45	30	15	184	17	125





Brušenje in ostrenje orodij LESNI PROGRAM

DIACOM 1SM

D x W x U/Z x H
Brusno orodje - disk

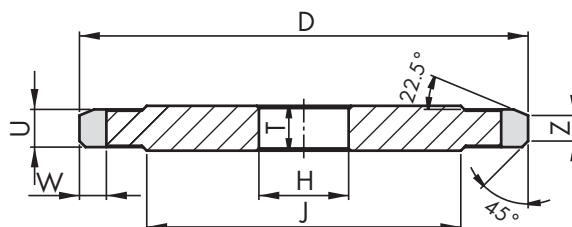

d	D	Z	W	T	U	J
4	75	0.9	6	4.5	7	51
6	75	1.9	6	4.5	7	51
8	75	2.8	6	5	7	51
10	75	3.7	6	6.4	7	51
12	75	4.7	6	7.4	7	51
14	75	5.7	6	8.4	7	51

premeri svedrov mozničarjev

DIACOM VD-4B9

D x X x U x H
Brusno orodje - disk

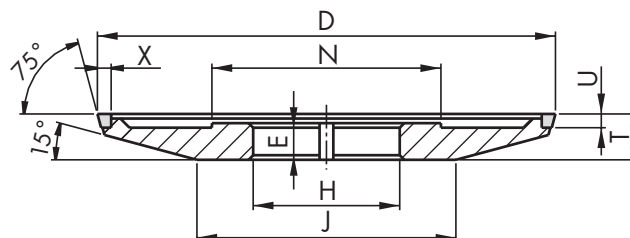

D	U	X	H	T	E	N
75	3	3	*	10	8	50
100	1.8	3	*	9	8.2	50
100	3	3	*	10	8	50
100	3.8	3	*	10	7.2	50
100	4	4.5	*	10	7	50
125	1.8	3	*	12	11.2	62
125	3.8	3	*	14	11.2	62
150	1.8	3	*	12	11.2	75
150	3.8	3	*	14	11.2	75

* Izdelujemo bruse s premerom luknje H=25mm in utorom 3x5 (označene kot VD) in H=32mm brez utorov (označene kot VB). Ostale vrednosti za U in X dimenzije, izdelujemo po dogovoru.



DIACOM **VD 6A2-DV**

Brusno orodje - lonec

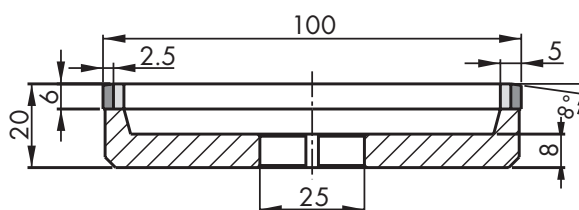

DIACOM **VB 6A2-DV**

Brusno orodje - disk

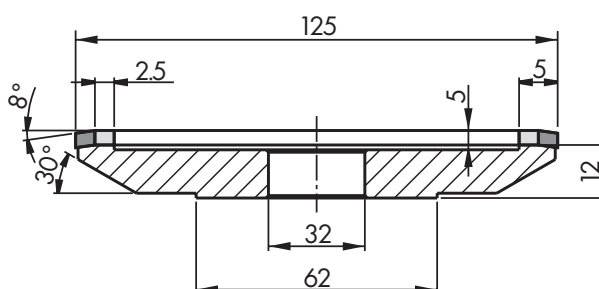



Brušenje in ostrenje orodij LESNI PROGRAM

DIACOM **VD-12A1**

Brusno orodje - krožnik

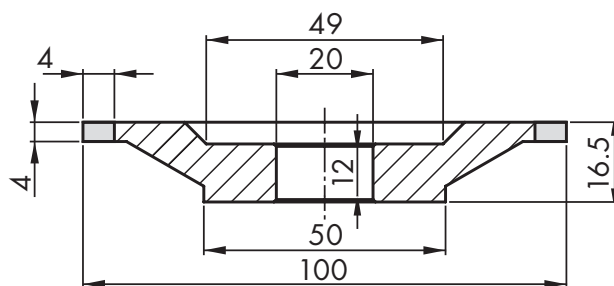

DIACOM **US-1A1W**

Brusno orodje - čep

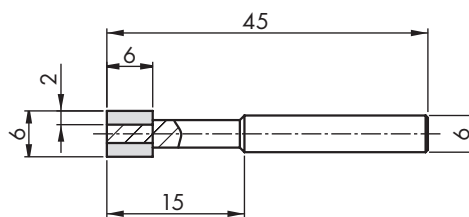



DIACOM **VB-12B9**

Brusno orodje - disk

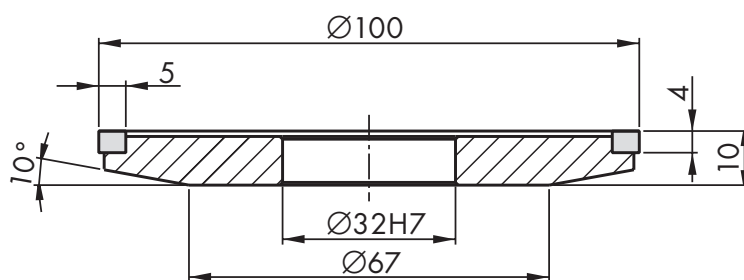

DIACOM **US-12V9**

Brusno orodje - lonec

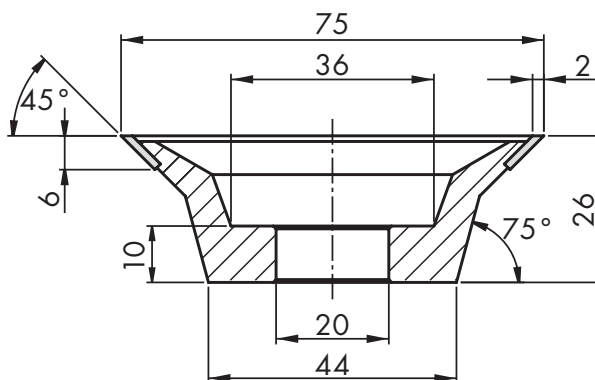

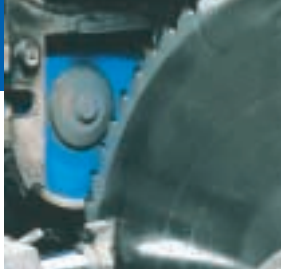

Brušenje in ostrenje orodij LESNI PROGRAM

DIACOM LL-11V2

Brusno orodje

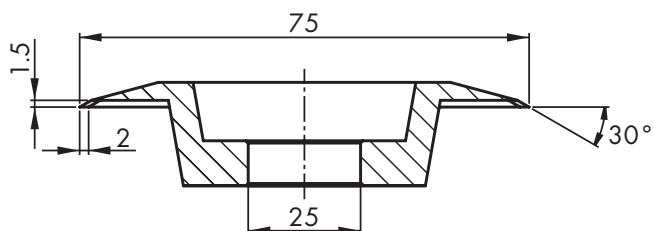

DIACOM LL-12A2

Brusno orodje - krožnik

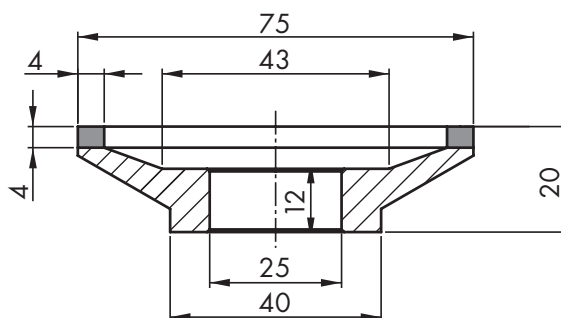

DIACOM LL-12A2-DV

Brusno orodje - krožnik



Tabela priporočljivih kвалitet brusov za brušenje in ostrenje orodij

04



Obdelovani material	Vrsta zrna	Granulacija	Vezivo	Koncentracija	Opombe
Jekla  Orodna Hitrorezna (HSS)	B B	46 - 126 46 - 126	BME , V80 BMRT, V80	100 - 125 100 - 125	V80 za mokro brušenje
Trdine  Karbidna trdina	D	46 - 151	BMR, BMRT V80	75 - 125	
PCD,PCBN 	D	10 - 30 mikronov	RJK, BR	100 - 125	
Stelit 	B	64 -126	BMR, BMRT	75 - 100	

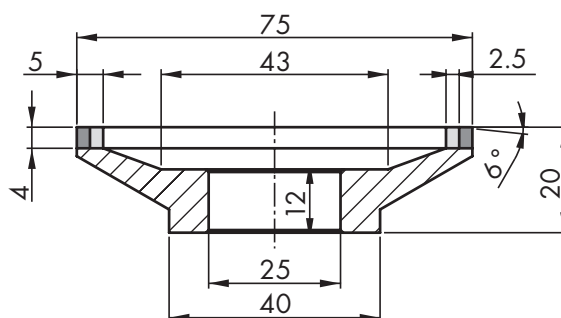